



DUSTEX<sup>®</sup> Water Dispersion- and  
Water Spraying Systems for the  
suppression of industrial dusts

# DUSTEX® ...for a dust-free environment



Plant without DUSTEX®



Plant with DUSTEX® in operation

## Dust, immense...

At many installations it is often necessary to either stop or limit production, even completely encapsulate certain areas to enable air cleaning to be carried out. Otherwise it is dangerous for the employees or aggressive towards the environment and the local neighbourhood. The criteria of permitted values of dust are getting more and more severe. A right for clean air is developing.

With all these factors in mind, the DUSTEX® system has been developed to supply a cheap and effective weapon against dust-laden air.

It has been known since long, that heavily dust-laden air can be cleaned by atomization, with very fine water particles. Normally no special wetting agents or additives are needed.

Ordinary water nozzles form fine particles, but create an uneven range of drop size and above all do not achieve the required fineness. The environment becomes more wet than the dust.

Even high pressure nozzles with pressures in excess of 50 or even 300 bar have little success, showing high wear rates and high installation costs.

Larger water drops have a much higher air-speed and a higher surface tension. They are hardly able to combine with the fine dust particles and to react with them.

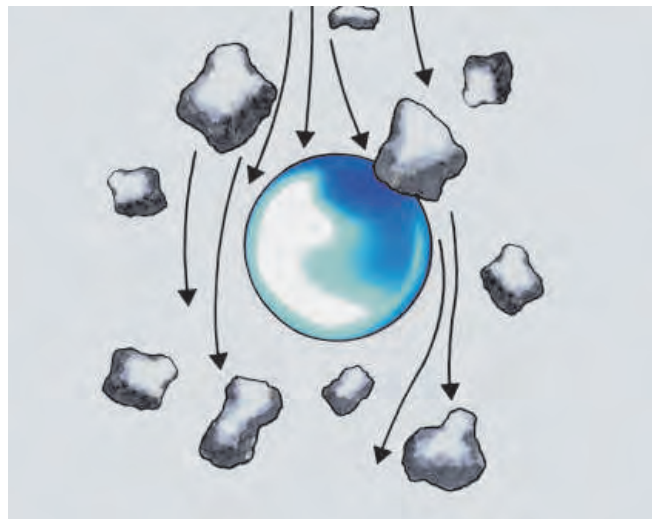
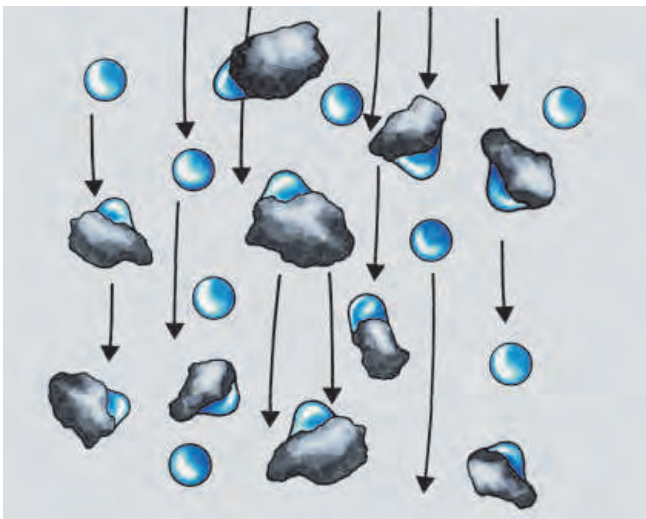

The different influences of large and fine water droplets on the dust binding behaviour: Small droplets settle down to the dust particles, form conglomerates and fall down, large droplets only displace the dust particles

# DUSTEX® Dispersion and Water Spraying Systems

## DUSTEX® Water Dispersion Systems

These systems work with two-material nozzles at low pressures with the media water and compressed air. Water is split up in micro-fine drops (10 up to 50  $\mu\text{m}$ ) by air pressure in an ultrasonic field. Thus, a maximum drop quantity and drop surface is gained out of the sprayed water.

They are particularly suitable when:

- very low emission values have to be observed
- the water consumption should remain low
- the humidity addition is not allowed to exceed the thousands limit
- the product is thermally treated later on

## DUSTEX® Water Spraying Systems

These systems work with one-material nozzles, only with the medium water.

They produce fine up to micro-fine drops with pressure of 4 to 10 bar.

They are particularly suitable when:

- low emission values have to be realized
- a slightly higher water consumption is no problem
- a higher humidity in the product is no problem, or even requested
- the plant cannot or hardly be encapsulated
- the product has to be loaded and unloaded several times

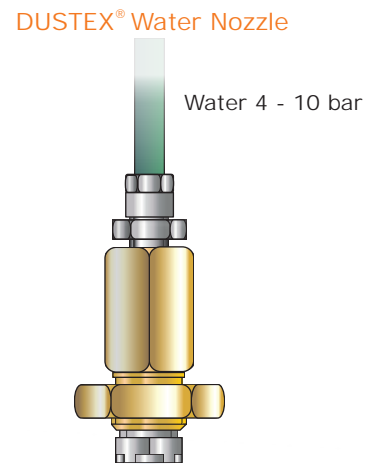
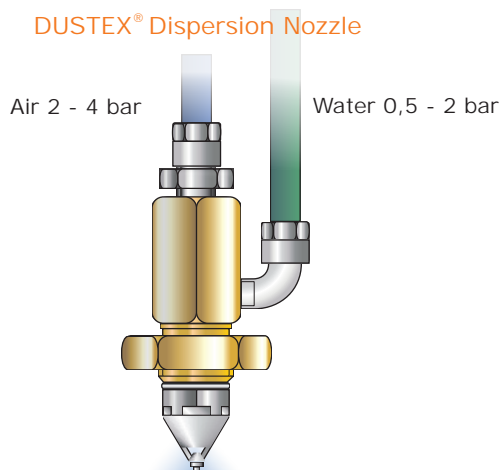

## Winter operation

It is well known that fog drops below 20  $\mu\text{m}$  cannot freeze. This applies to the DUSTEX® process as well, so it can also be operated in winter. Because of the danger of freezing during standstill the system should

be automatically dewatered after switching off. Control cabinet and water pipings have to be heated and isolated during operation. Therefore, isolating and heating components are available.



# DUSTEX® Conditions of application

## Materials and fields of applications:

The following materials are particularly suited for the DUSTEX® treatment:

coal, coal dust, ore, waste molding sand, gravel, sand, lime and crushed stone, fly ash, chemical products, alum earth, fertilizer, agricultural products, domestic waste.

These are the fields of applications:

- Installations for material treatment by crushers, sieves, blenders, pelletizers, classifiers and conveyor belt transfers
- Installations for feeding material Filling of stock piles and tip bunkers, ship loading by telescope chutes, vehicle loading from silos
- Silos, stock houses, material depots workshops, where dust has to be quickly removed for inspection or other operations
- Installations for removal of material by drilling, milling, sand blasting
- Danger of Combustion/ Fire, Dust Explosion Zones Removal of the critical conditions for the starting and spreading of fires and explosions
- Chemical and Biological Processes Atomizing of aerosols or water with additives for gas cleaning and gas reaction or for removal of odours.

## DUSTEX® Installation

For the best effect from any dust suppression system it is important to achieve the correct water atomization along with a consistently correct droplet size and speed, from strategically placed nozzles.

It is also important to be aware that the satisfactory effect can only be achieved when the fog "lobes" are adjusted to fill the working area and are allowed to mix with the dust undisturbed, over the correct period of time. This can be achieved by the following measures:

- In the specially designed stainless steel fog nozzle the spraying angle of the DUSTEX® nozzle can be adjusted through 60° via turning the angle adapter, all without changing the installation position of the fog nozzle itself
- By encapsulating and other measures such as guiding plates and aprons, the air stream has to be reduced to less than 0,5 m/sec and redirected
- To allow a sufficient dust fog reaction area the encapsulation has to be enlarged to give a reaction zone of 0,4 up to 1,2 m height and about 1m<sup>3</sup> volume per nozzle
- Thanks to nozzle devices with nozzles installed at a distance of about 0,5m and a depth of effect of up to 5 m, large dust emission areas can be managed.

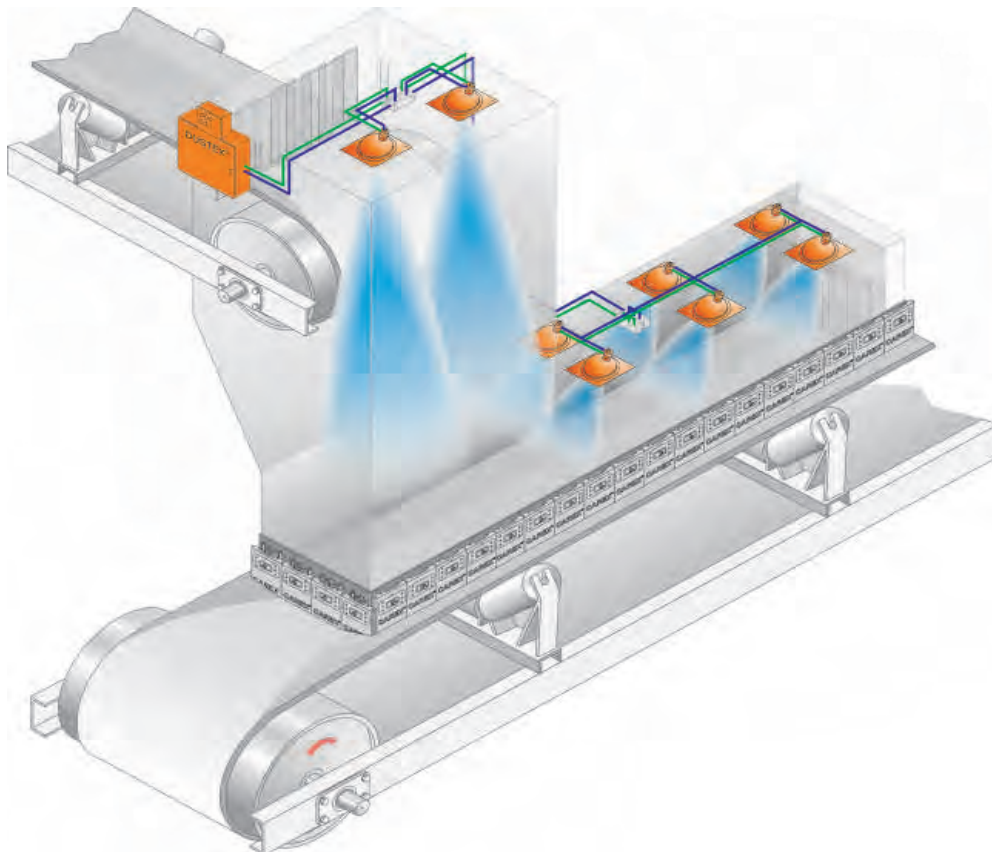

# DUSTEX<sup>®</sup> Examples of Application

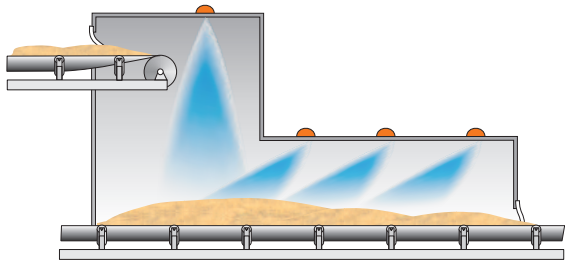

conveyor belt transfers

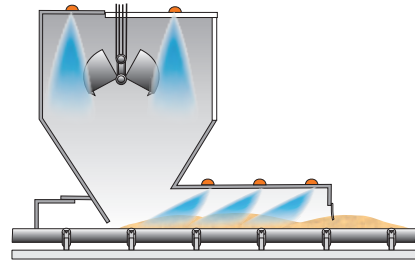

grab operation

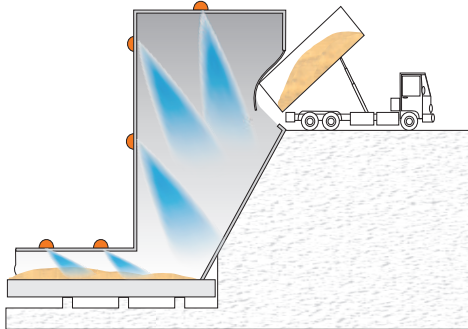

tip-truck bunkers

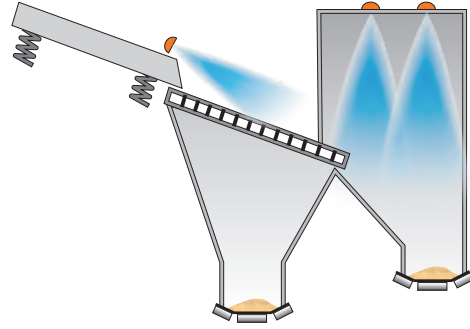

screens, sieves

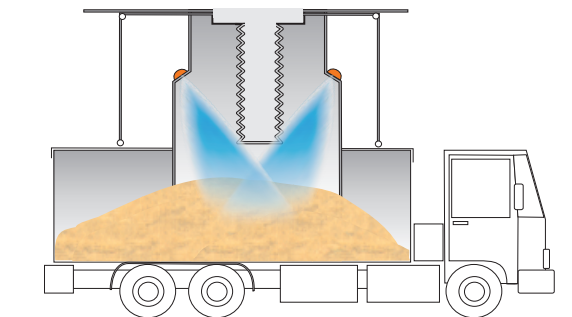

truck loading

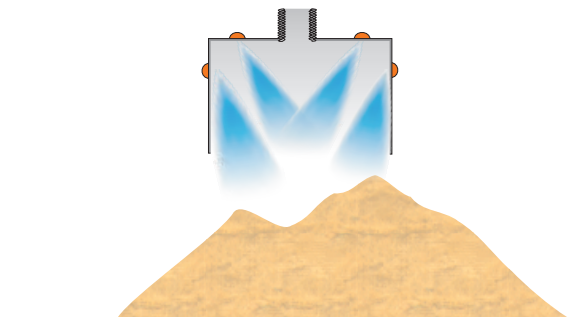

ship loading, stockpiling

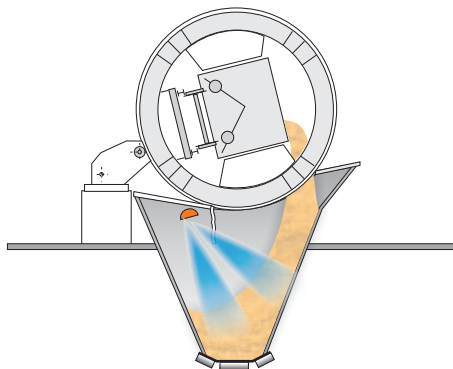

railway pit bins

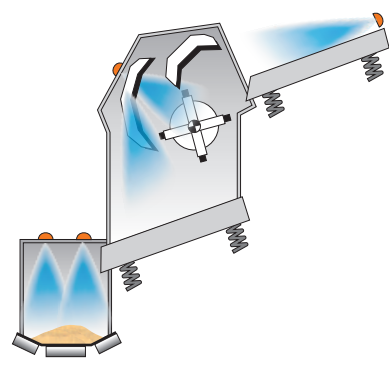

crusher



# DUSTEX® Components

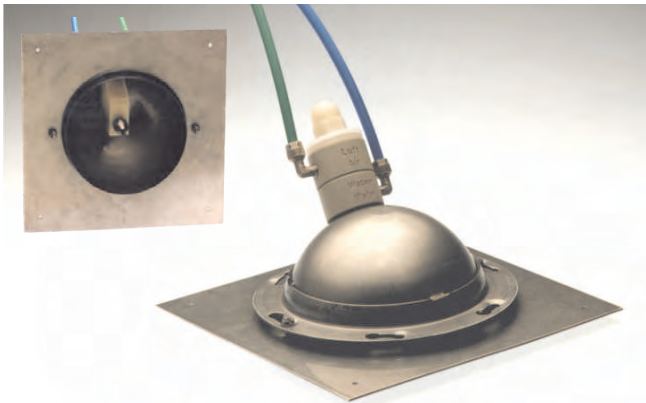

Nozzle Cupola with nozzle adapter for universal adjustment



Nozzle Device: Pipe length and number of nozzles are variable

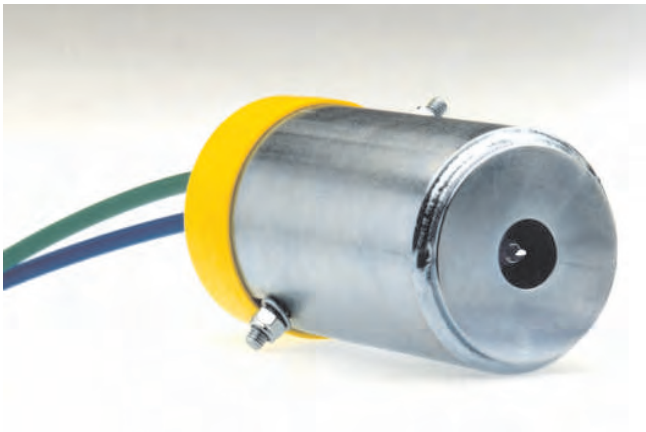

Fog pipe, Protection pipe to be welded



Control unit SEC

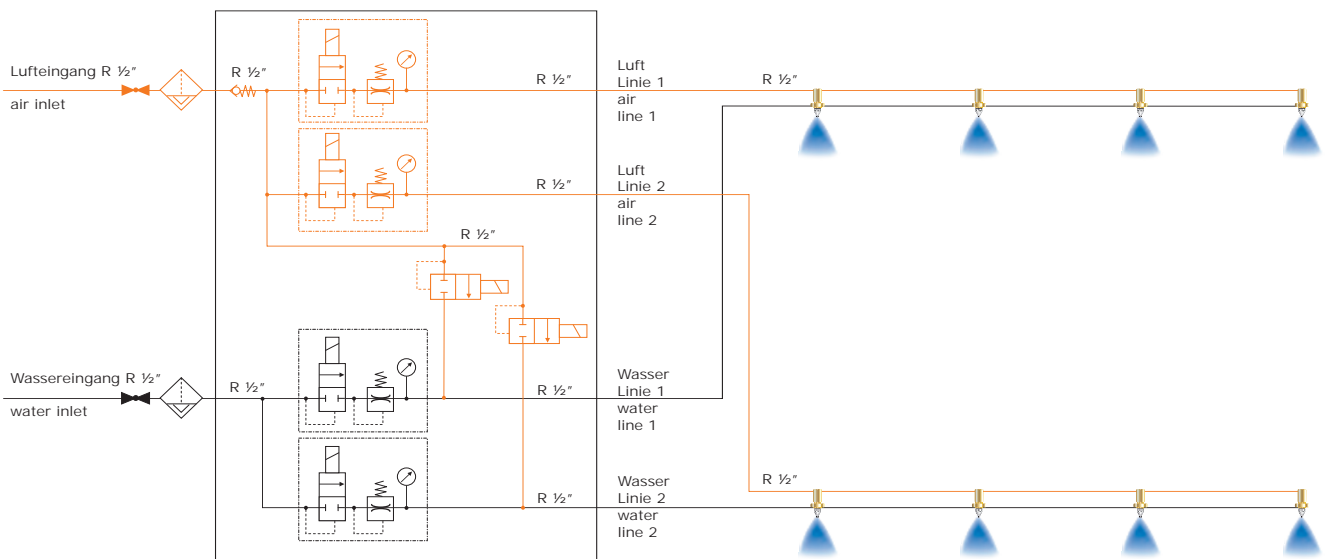

Control scheme for installations with 2 independent nozzle systems.  
 With DUSTEX® Water spraying systems, there are no air lines.

# DUSTEX® Water Dispersion Nozzles, media consumption

**Dispersion nozzle 1005**  
for small plants with  
low material flow rate

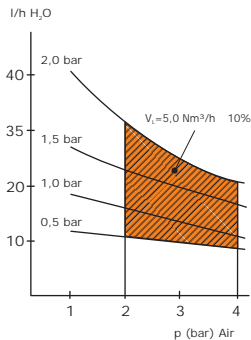

**Dispersion nozzle 2507**  
for normal applications  
in encapsulated plants

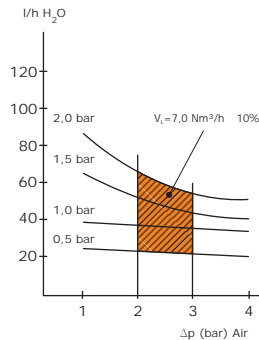

**Dispersion nozzle 5510**  
for large and non-  
encapsulated plants

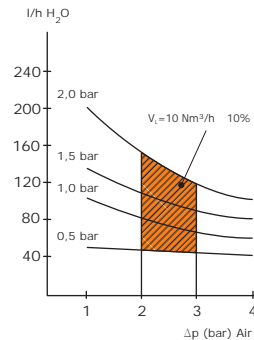

**Spectrum of droplets**

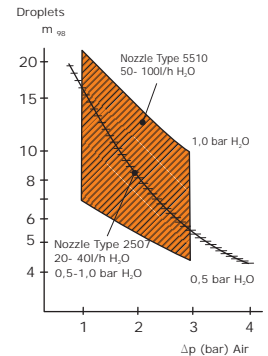

Air consumption ( $\text{Nm}^3/\text{h}$ ) and water atomizing performance ( $\text{l/h}$ ) as function of the air pressure at different water pressure (bar) measured in a switch case with 3 m hose 8x1 mm.



There are 3 different sizes of DUSTEX® nozzles, which have a water penetration of 5- 120  $\text{l/h}$  depending on the pressure. The water pressure is adjusted to 0,5- 2 bar overpressure. Common values are 25 $\text{l/h}$  (adjusted values: 0,5 bar water pressure / 2 bar air pressure) with the dispersion nozzle type 2507. The consumption of compressed air per nozzle is 5- 12  $\text{Nm}^3/\text{h}$  in an overpressure range of 2- 4 bar. For DUSTEX® Water Spraying System, there are one material nozzles available of any water flow rate requested.

## The Advantages of the DUSTEX® System

- Stunningly high effectiveness, often also in "unsolvable" problem cases
- Low consumption of water and compressed air
- The addition of 1 ltr. water only to 1 ton material
- Little mounting expense
- Robust, universal, and easy-to maintain system parts
- Anti-freezing device against disturbances in low temperature operation
- Self cleaning of the nozzles by ultra sonic effect.

Make your decision for more cleanness and environmental protection. Ask the specialists of VSR for a complete project study or a trial application.

With special agreement in case the effect of our system is not satisfactory, we will take back the system within 4 weeks after delivery or mounting franco to our premises at the invoiced price.



# Product programme

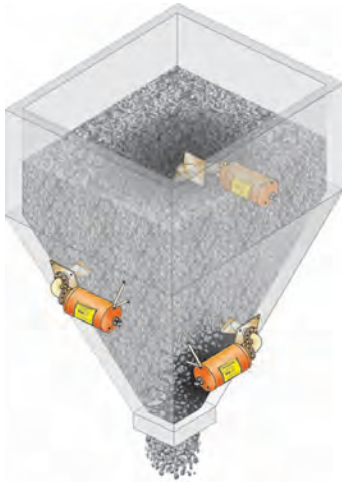

VSR BLASTER® Air cannons and air injectors

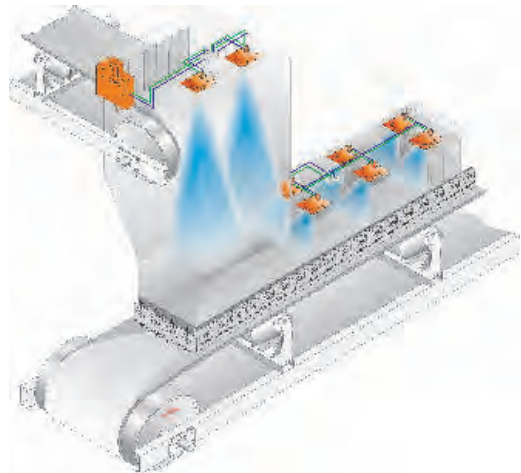

DUSTEX® Dust suppression system

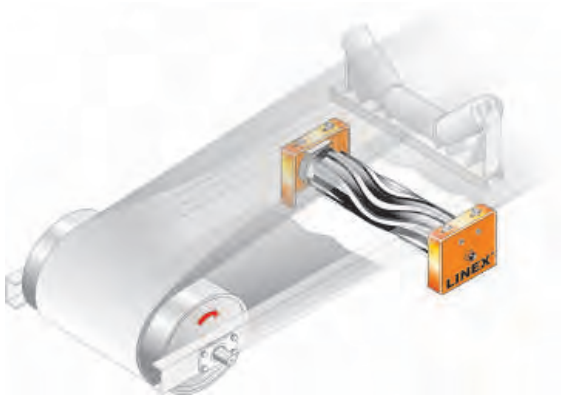

LINEX® Conveyor belt centralizing idler

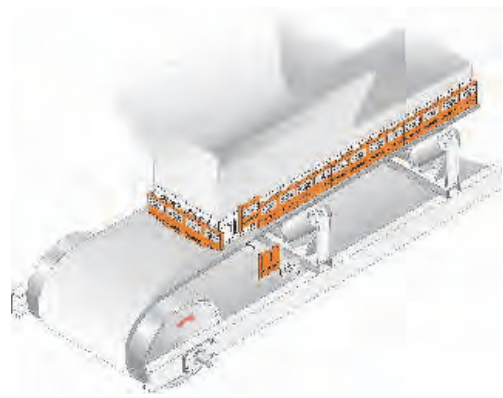

CAREX® sealing of conveyor belt transfers

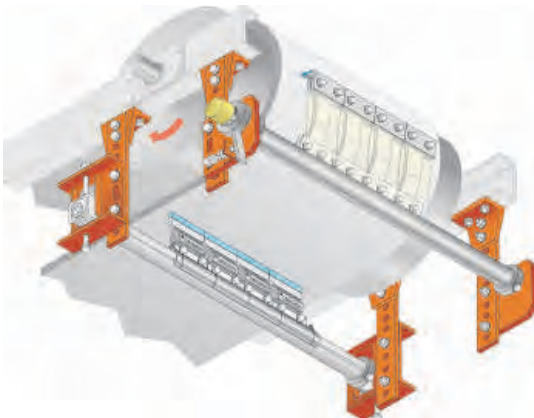

VIBREX® Conveyor belt cleaning

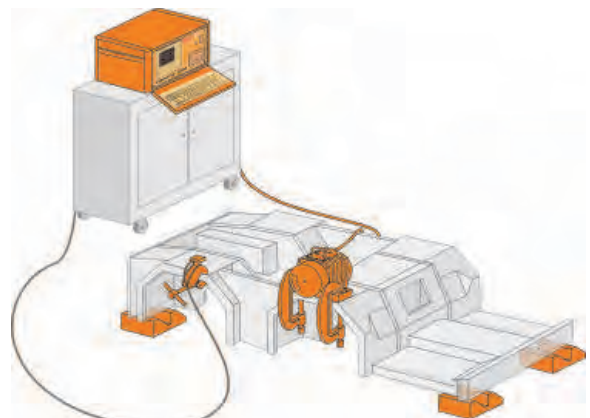

VIBMATIC 6000® Vibration stress reduction

# VSR



VSR Industrietechnik GmbH  
Am Alten Schacht 6  
D- 47198 Dulsburg  
Tel. +49 (0) 20 66 / 99 66-30  
Fax +49 (0) 20 66 / 99 66-62

Internet: [www.vsr-Industrietechnik.de](http://www.vsr-Industrietechnik.de)

E-mail: [Info@vsr-Industrietechnik.de](mailto:Info@vsr-Industrietechnik.de)